



**Power on the go!**

**8ZED Power Inverter**

Installation Manual and  
Operating Instructions

**Converts 12 Volts DC to 220/230/240 Volts AC**

## INTRODUCTION

To get the most out of your 8ZED Inverter, proper installation is **critical**. Please read the installation and operating instructions in this manual carefully before installing and using your 8ZED Inverter. Pay special attention to the **CAUTION:** statements in this manual.

**CAUTION:** statements identify conditions or practices which could result in damage to your 8ZED Inverter or to other equipment. Proper procedures not followed could result in the warranty becoming void.

## INTRODUCTION

The power source must provide between 11 and 15 volts DC and must be able to supply sufficient current to operate the load. As a rough guide line, divide the power consumption of the load (in watts) by 10 to obtain the current (in amperes) that the power source must deliver.

**CAUTION:** *The 8ZED Inverter should not be used while driving your vehicle using the alligator clips.*

**CAUTION:** *The 8ZED Inverter must be connected only to batteries with a normal output voltage of 12 volts. The 8ZED Inverter will not operate from a 6 volt battery and will be damaged if it is connected to a 24 volt battery.*

**CAUTION:** *Rechargeable batteries and devices with rechargeable batteries may not be suitable for use with the 8ZED Inverter. The rechargeable batteries, recharging transformer and/or the 8ZED Inverter may be damaged when trying to recharge devices of 10 volts and higher. Refer to the manufacturers specifications when using these devices.*

## SUITABLE POWER SOURCE

In order to operate the inverter and supply power to an appliance a suitable 12V DC power supply is required. This can be a vehicle, boat or caravan battery, portable power pack or an independent 12V lead acid battery. For most applications, a deep cycle battery is recommended for best performance.

## BATTERY OPERATING TIME

The typical vehicle battery has a minimum operating time of 1 to 2 hours, depending on the current use of the load being driven and the size of the battery. We recommend that the operator start the vehicle every hour to recharge the battery system. This will prevent unexpected shut downs of equipment and will ensure that there is always sufficient battery capacity to start the engine.

## PLACEMENT OF THE INVERTER

For best operating results, the 8ZED inverter should be placed on a flat surface, such as the floor or seat of the vehicle. The inverter should only be used in locations that meet the following requirements:

- A.) DRY – Keep away from water. Do not allow water to drip or splash on the 8ZED Inverter.
- B.) COOL – Ideal ambient air temperature should be between 10 degrees and 33 degrees C (50 degrees and

90 degrees F). Do not place the inverter on or near a heating vent or any piece of equipment which is generating heat above room temperature. If avoidable, do not place the inverter in direct sunlight.

- C.) VENTILATED – Allow at least two inches of clearance around the 8ZED Inverter for air flow. Do not place anything on or over the inverter during operation. Make sure that the air is allowed to circulate freely around the unit.
- D.) SAFETY – Do not use the 8ZED Inverter near flammable materials or in any location which may accumulate flammable fumes or gases, such as the battery compartment of your car, truck, RV or boat. This product is not suitable for use while travelling using battery clamps. The length of the wire cables and battery clamps are not designed for this operation. If you wish to operate the 8ZED inverter while moving, it must be permanently mounted and wired.

## CONNECTING TO THE POWER SOURCE

**CAUTION:** *Before making any connections ensure inverter is switched off and has no AC appliances plugged into the AC output sockets.*

- Connect the ring terminal on the negative lead (Black) to the negative (Black) DC terminal on the back of the inverter.
- Connect the battery clip (Black) or ring terminal on the other end of the lead to the negative DC supply or (-) battery terminal.
- Connect the ring terminal on the positive lead (Red) to the positive (Red) DC terminal on the back of the inverter.
- Connect the battery clip (Red) or ring terminal on the other end of the lead to the positive DC supply or (+) battery terminal.

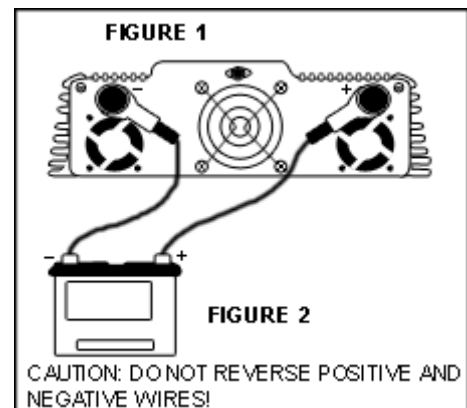

FIGURE 1- Loosen the caps on the terminals and slide the lugs between the cap and the base. Then tighten firmly.

FIGURE 2- for the appropriate terminal connections.

## “HARD WIRED” CONNECTION

When mounting the inverter in a vehicle, caravan, boat or cabin it may be preferable to use longer DC battery cables than those supplied, so that the inverter can be placed in a more convenient, cooler or more protected location.

If longer cables are required only use suitably insulated automotive battery cable according to the following table.

(AWG = American Wire Gauge)

P/No	8ZED 300W	8ZED 600W	8ZED 1200W	8ZED 1800W	8ZED 2400W	8ZED 3000W
Up to 2m	8 AWG	6 AWG	3 AWG	2 AWG	0 AWG	00 AWG
3m	8 AWG	3 AWG	2 AWG	0 AWG	00 AWG	Not advised
4m	6 AWG	2 AWG	0 AWG	00 AWG	Not advised	Not advised
6m	3 AWG	0 AWG	00 AWG	Not advised	Not advised	Not advised

It is recommended that a circuit breaker or high current fuse be placed in the DC positive (+) line close to the battery.

P/No	8ZED 120W	8ZED 300W	8ZED 600W	8ZED 1200W
Fuse/circuit breakers size (+) only	15 AMP	35 AMP	60 AMP	110 AMP

P/No	8ZED 1800W	8ZED 2400W	8ZED 3000W
Fuse/circuit breakers size (+) only	250 AMP (or 2x 150A in parallel)	2x 200 AMP	2x 250 AMP

It is also recommended that a heavy duty battery switch with a current rating higher than the fuse (or combined fuses) be fitted in the DC positive (+) line close to the battery to allow the supply to the inverter to be switched off, this can also be achieved by using a circuit breaker which has a trip facility.

Positive and negative cables should be run close together to reduce cable inductance, and be protected from damage by corrugated conduit.

### GROUND CONNECTION

The chassis ground lug must be connected to a grounding point. In a vehicle, connect the chassis ground lug to the vehicle's chassis. In a boat connect to the grounding system of the boat. In a fixed location connect to the ground.

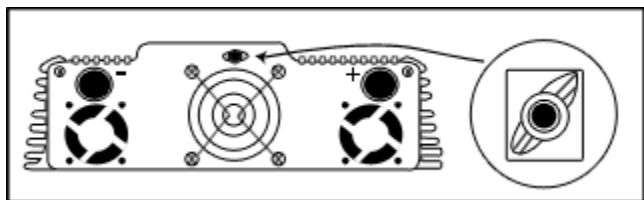

### OPERATING TIPS

Most electrical tools, appliances and audio/video equipment have a label indicating power consumption in amps or watts. Add up the power consumption in those items you will be using simultaneously, keeping total below the 8ZED Inverter size. If the power consumption is rated in amps, multiply by the AC volts (220/230/240) to determine the wattage. For example, a television rated at 0.9 amps will use approx 99 watts. For more information regarding the typical wattage draws of many appliances, refer to [8zed.com](http://8zed.com).

Resistive loads, such as incandescent lights, are the easiest for the inverter to drive, though larger resistive loads, such as electric stoves or heaters, require more power. Please make sure you choose the right 8ZED Inverter to suit the application you need in order to power the appliance continuously. Inductive loads, such as TV's and stereos (any device with a coil or a transformer in it) require more current to operate than a resistive load of the same power rating. Induction motors (motors without brushes), as well as some televisions, may require **2 to 6 times** their power rating to start up. This condition may require repeated "ON/OFF, ON/OFF, ON/OFF" switching of the power switch on your 8ZED Inverter in order to get them started. The most demanding are those that start under load, i.e. compressors and pumps. Since motor and television characteristics vary widely, only experimentation will determine if a specific load can be started and how long it can be run.

There are no standards for "surge power" partly because it can not be simply represented by a single sample number. Though our 8ZED Inverters can provide power up to 6000W (depending on the unit you purchase) for a **short** period, experimentation is the only method of determining whether it can handle the surges generated by a particular load.

**IMPORTANT NOTE:** The 8ZED 120W to 1200W Inverters won't operate most appliances designed to produce heat such as hair dryers, coffee makers, irons, heaters and toasters. The current use of most of these exceeds 1200 watts, far beyond the capacity of the units listed above. The inverter may be used either while the engine is running or turned off. However, the inverter may not operate while the engine is starting, since the battery voltage can drop substantially during engine cranking. The 8ZED Inverter draws less than 1.3 ampere from the battery when it is not supplying power to the load. In most cases, the 8ZED Inverter may be left connected to the battery when it is not in use, since it draws so little current. If the vehicle will not be used for several days, disconnect the 8ZED Inverter from the battery.

### CONNECTING APPLIANCE & RUNNING INVERTER

- Connect the appliance AC plug to the inverter AC outlet socket.
- Switch the inverter "ON", the Green power light will illuminate to indicate operation.
- Turn the appliance "ON", if the appliance is fitted with an "On/Off" switch always switch the inverter on before switching the appliance on and always turn the appliance off before switching the inverter off.
- When not in use turn the inverter off.

### LOW BATTERY ALARM

An alarm will sound when the voltage of the battery drops to 10.5 volts. This indicates that the battery requires recharging. The user should stop operations at this time, since the 8ZED Inverter will shut down automatically when battery voltage drops to 10.0 volts.

If the low battery alarm sounds when the battery is fully charged, follow these steps for correcting the lack of output power: Reduce the load on the inverter and keep the voltage above 11.5 volts to maintain regulation. The alarm will sound when the inverter is overloaded, or if there is an excessive voltage drop between the battery and the inverter.

**NOTE:** *The alarm may sound momentarily when the unit is being connected to, or disconnected from, the power source. This is normal and does not indicate any problem.*

## INDICATORS AND CONTROLS

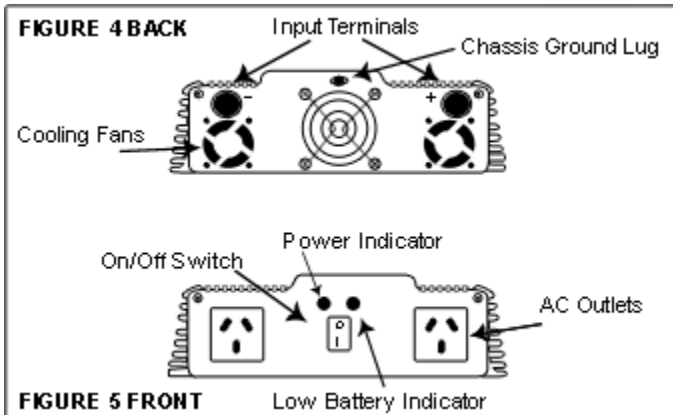

## PROTECTION FEATURES

**Your 8ZED Inverter circuitry constantly monitors the following hazardous conditions:**

- A.) Low Battery Voltage – This condition is not harmful to the inverter, but could damage the power source. An audible alarm is sounded when input voltage drops to 10.5 volts. When the condition is corrected (i.e. alternator charges battery) the unit may be restarted.
- B.) Short Circuit - Reverse polarity or short circuit condition of the load will usually result in opening of the short circuit protection and blowing the three 35 amp fuses.
- C.) High Temperature – When the temperature of the internal heat sinks reaches 66 degrees C (150 degrees F), the solid state temperature sensor located in the 8ZED Inverter will automatically shut down the unit. Once it is allowed to cool, it may be restarted.

## TROUBLESHOOTING GUIDE / FAQ

**Q. The inverter will not run my appliance even though the listed power is less than the inverter size**

A. Electrical appliances can be separated into three loads by the way they draw energy (current) from their power supply. These loads are “Resistive”, “Inductive” and “Capacitive” appliances. Some appliances may draw all three types of power, in which case all should be considered.

- **Resistive Loads** such as normal incandescent lights (wire filament) always draw a constant power (watts) from the power supply, that is a 100 Watt light will draw approximately 100 Watts from the power supply at all times. Resistive loads are the easiest appliances for an inverter to run.

- **Inductive Loads** such as a fridge (electric motor) require a large rush of power (surge current) to start and then usually draw a more constant power once running. Inductive loads contain coils of wire (motors, transformers, ballasts, solenoids). When the power is first turned on these coils of wire draw a large surge current which forms the magnetic flux which allows these appliances to work. The magnetic flux is a kind of stored energy. Most common inductive appliances are: fridges, air compressors, transformers, pumps, power tools & fluorescent lights. These appliances can draw 2-6 times their normal running power to start up. To run a 200 Watt fridge you may need a 600 to 1200 Watt 8ZED inverter.
- **Capacitive Loads** such as TV’s may require a large surge current to start only when they have not been used for a while. This is often due to large capacitors in the power supply that must be quickly charged when the appliance is turned on. If the appliance is not used for a few days these capacitors slowly go flat. Resetting the inverter a couple of times may allow these appliances to work.
- Some appliances such as large fridges, air conditioners and other pump driven appliances have extremely high start up currents, because they have an inductive motor that must start under load. These appliances are not recommended for use with an inverter. They should be powered by an engine driven generator.

**Q. Why is it important to make sure that the battery leads are not connected back to front?**

A. The 8ZED inverter uses highly developed electronics to convert DC battery power to AC mains power. If you accidentally connect the inverter to the battery incorrectly a large current will be drawn by the inverter which will blow the protection fuses, as this occurs some of the high current could damage the sensitive electronic components. Because of this risk it is important to always double-check the battery polarity before making any connections.

**Q. Why do some power tools not work properly?**

A. Some newer power tools use PWM variable speed controllers to vary the tool’s speed as the trigger is squeezed. These power tools switch the power on and off very quickly in a similar way to how the inverter works. Because of this, some may not function properly with the inverter’s modified sine wave output.

**Q. Can I connect lights with dimmers to the inverter?**

A. Older light dimmers may function fine but most newer light dimming circuits are designed for household sine wave AC power, these may not work properly with modified sine wave inverters.

**For more inverter FAQ’s, visit [8ZED.com](http://8ZED.com)**